

SPECIFICATION	CONNECTION	BIPOLAR
AMPS/PHASE		1.80
RESISTANCE/PHASE(Ohms)@25°C		2.55±10%
INDUCTANCE/PHASE(mH)@1KHz		12.00±20%
HOLDING TORQUE(Nm)[lb-in]		2.40[21.24]
STEP ANGLE(°)		1.80
STEP ACCURACY(NON-ACCUM)		±5.00%
ROTOR INERTIA(g-cm ²)		680.00
WEIGHT(Kg)[lb]		—
TEMPERATURE RISE:MAX.80°C (MOTOR STANDSTILL;FOR 2PHASE ENERGIZED)		
AMBIENT TEMPERATURE -10°C~50°C[14°F~122°F]		
INSULATION RESISTANCE 100 Mohm (UNDER NORMAL TEMPERATURE AND HUMIDITY)		
INSULATION CLASS B 130°C[266°F]		
DIELECTRIC STRENGTH 500VAC FOR 1MIN.(BETWEEN THE MOTOR COILS AND THE MOTOR CASE)		
AMBIENT HUMIDITY MAX.85%(NO CONDENSATION)		

TYPE OF CONNECTION (EXTERN)		MOTOR	
PIN NO	BIPOLAR	LEADS	WINDING
1	A+ —	BLK	
2	A- —	GRN	
3	B+ —	RED	
4	B- —	BLU	

FULL STEP 2 PHASE-Ex. ,
WHEN FACING MOUNTING END (X)

STEP	A+	B+	A-	B-		
1	+	+	-	-	↓	CCW ↑
2	-	+	+	-		
3	-	-	+	+	↑	CW ↓
4	+	-	-	+		

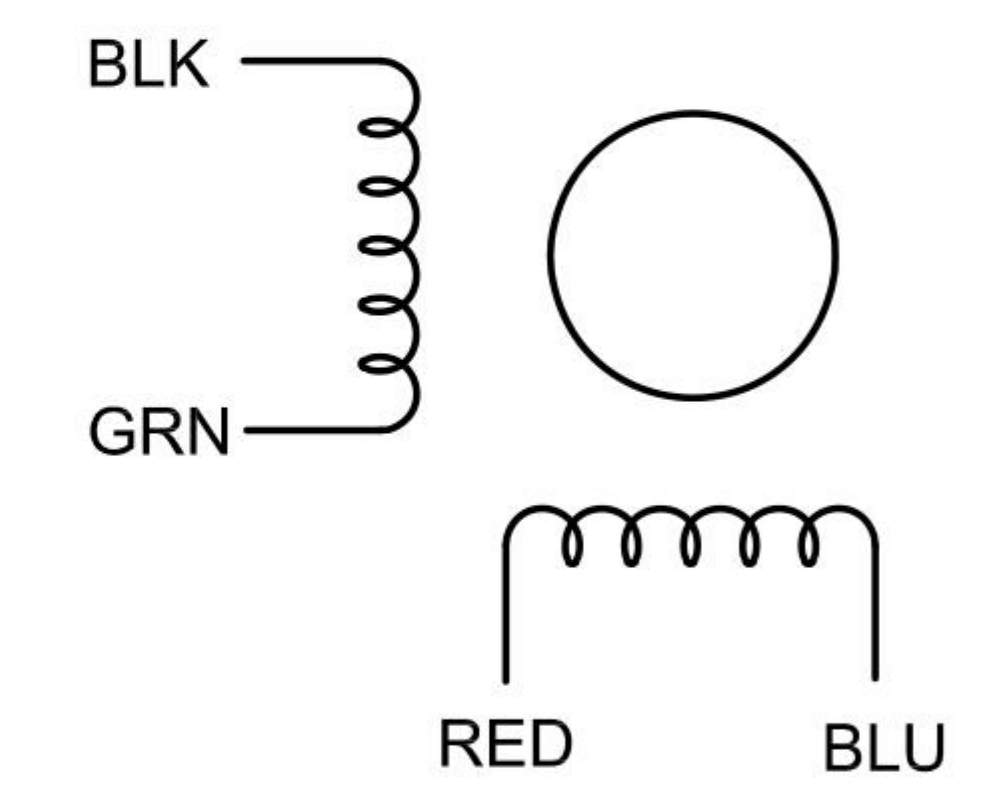

	APVD	10.30.2020
	CHKD	
1:1.5	DRN	
SCALE	SIGNATURE	DATE

STEPPER MOTOR

23HB41-1804S_Full