

REV.	REVISION RECORD	BY	DATE
0	ORIGIN	PJ	6.1.2023

CUSTOMER'S MODEL: NO MODEL  
 END COVER COLOR: BLACK

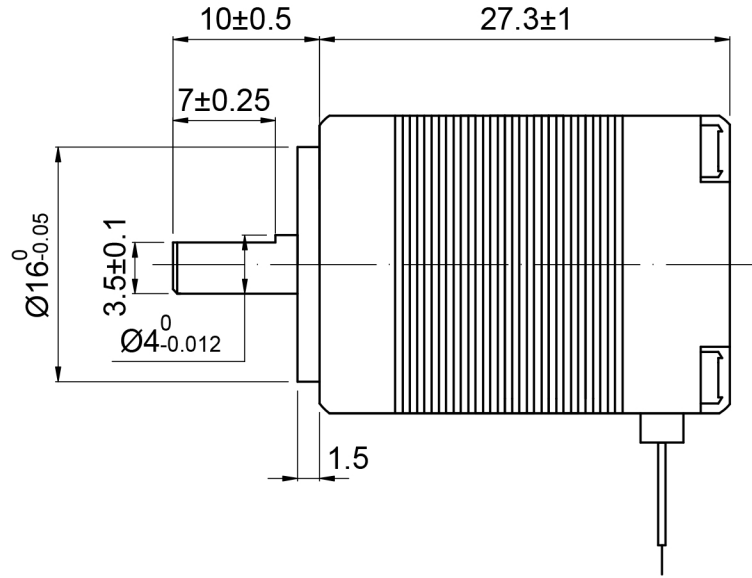
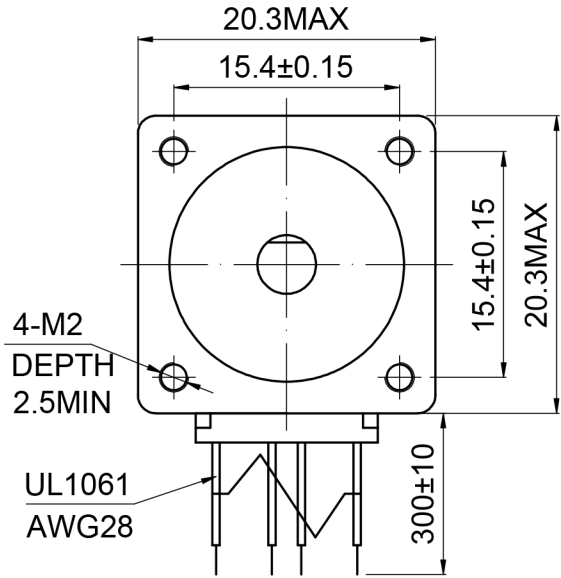

SPECIFICATION	CONNECTION	BIPOLAR
AMPS/PHASE		0.20
RESISTANCE/PHASE(Ohms)@25°C		24.00±10%
INDUCTANCE/PHASE(mH)@1KHz		8.00±20%
HOLDING TORQUE(Nm)[lb-in]		0.014[0.12]
STEP ANGLE(°)		1.80
STEP ACCURACY(NON-ACCUM)		±5.00%
ROTOR INERTIA(g-cm <sup>2</sup> )		2.50
WEIGHT(Kg)[lb]		—
AMBIENT TEMPERATURE		-10°C~50°C[14°F~122°F]
INSULATION CLASS		B 130°C[266°F]
TEMPERATURE RISE		MAX.80°C

COMMENT:  
 1.DYNAMIC AXIAL LOAD: 10N MAX  
 2.DYNAMIC RADIAL LOAD @ SHAFT LENGTH 20mm: 21N MAX  
 3.TMBF 6000h OR MORE @ 24V/300RPM  
 4.INSULATION RESISTANCE (NORMAL TEMPERATURE AND HUMIDITY): 100 Mohm  
 5.DIELECTRIC STRENGTH 500VAC FOR 1MIN.(BETWEEN THE MOTOR COILS AND THE MOTOR CASE )

MOTOR CONNECTION			
PIN NO	BIPOLAR	LEADS	WINDING
1	A+	BLK	
2	A-	GRN	
3	B+	RED	
4	B-	BLU	

FULL STEP 2 PHASE-Ex., WHEN FACING MOUNTING END (X)					CCW	DIMENSIONS ARE IN MILLIMETERS. TOLERANCES AS BELOW: DECIMALS ANGLES X ±0.5 ±2° X.X ±0.25 X.XX ±0.13
STEP	A+	B+	A-	B-		
1	+	+	-	-	CW 	
2	-	+	+	-		
3	-	-	+	+		
4	+	-	-	+		



STEPPER MOTOR

8HB11-0204S

THIS DOCUMENT SHALL NOT BE REPRODUCED NOR SHALL THE INFORMATION CONTAINED HEREIN BE USED BY OR DISCLOSED TO OTHERS UNLESS EXPRESSLY AUTHORIZED IN BY WRITING STEPPERONLINE.

SIGNATURE		DATE
DRN	LDJ	7.26.2023
APVD	ZPJ	7.26.2023

REV.	0	SCALE	1:1	DWG NO.	A1716
------	---	-------	-----	---------	-------