

SPECIFICATION	CONNECTION	BIPOLAR
AMPS/PHASE		1.50
RESISTANCE/PHASE(Ohms)@25°C		2.80±10%
INDUCTANCE/PHASE(mH)@1KHz		3.80±20%
HOLDING TORQUE(Nm)[lb-in]		0.40[3.54]
STEP ANGLE(°)		1.80
STEP ACCURACY(NON-ACCUM)		±5.00%
ROTOR INERTIA(g-cm <sup>2</sup> )		54.00
WEIGHT(Kg)[lb]		—
TEMPERATURE RISE:MAX.80°C (MOTOR STANDSTILL;FOR 2PHASE ENERGIZED)		
AMBIENT TEMPERATURE -10°C~50°C[14°F~122°F]		
INSULATION RESISTANCE 100 Mohm (UNDER NORMAL TEMPERATURE AND HUMIDITY)		
INSULATION CLASS B 130°C[266°F]		
DIELECTRIC STRENGTH 500VAC FOR 1MIN.(BETWEEN THE MOTOR COILS AND THE MOTOR CASE )		
AMBIENT HUMIDITY MAX.85%(NO CONDENSATION)		

TYPE OF CONNECTION (EXTERN)		MOTOR	
PIN NO	BIPOLAR	LEADS	WINDING
1	A+ —	BLK	
2	A- —	GRN	
3	B+ —	RED	
4	B- —	BLU	

FULL STEP 2 PHASE-Ex. ,  
WHEN FACING MOUNTING END (X)

STEP	A+	B+	A-	B-		CCW
1	+	+	-	-	↓	↑
2	-	+	+	-		
3	-	-	+	+	↑	↓
4	+	-	-	+		

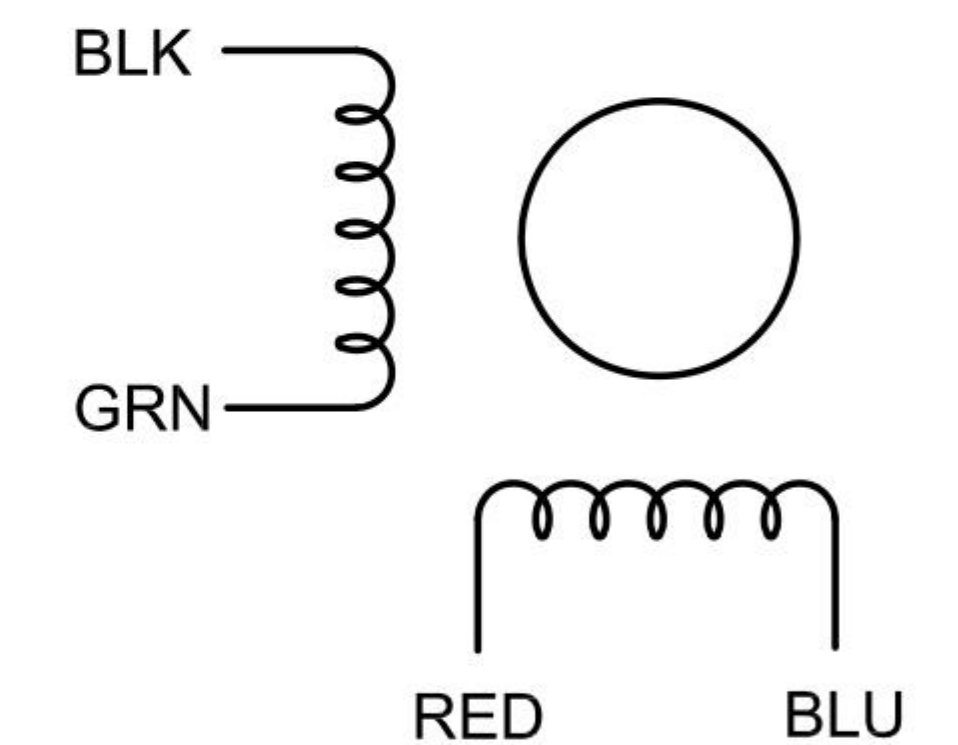

	APVD		10.30.2020
	CHKD		
1.5:1	DRN		
SCALE	SIGNATURE		DATE

STEPPER MOTOR

14HB20-1504S